

# SOLIMAR

Since 1985

## Silo Fluidizer

### Keep Dry Bulk Materials Moving

Solimar Pneumatics offer a family of Silo Fluidizers that promote the discharge of dry products from storage silos, dust collectors, weigh bins and IBC's. Solimar Fluidizers enable a uniform flow of most dry bulk materials through aeration and hopper wall vibration that helps prevent bridging, rat holing and compacting.



Patented Fluidizer used with over 120 different material types in 70 countries around the world.

### The Original & Best Disk Fluidizer

**Aeration** loosens up the product allowing it to flow easier. Minimum back pressure puts air energy where it is need the most – in the silo.

**Directional Air Flow.** The Fluidizer disk forces air to move along the bin wall freeing up product and assuring good cleanout.

**Gentle Vibration** keeps the product flowing without allowing it to compact or plug.

**No Airline Plugging.** Disk seals tightly against the silo wall and prevents airline plugging.

**Robust Design.** will not tear, pick up moisture & is unaffected by temperatures up to 450° F (230° C).

**Install From Outside.** Available **EZ-In (Easy-In)** kits for installation without getting inside the bin or replacing out dated screen pads.



**Material Compatible.** Multiple disk options, including silicone rubber food grade/FDA approved (blue or white), high temperature (orange), Metal Detectable (gray) & EPDM (black or white).

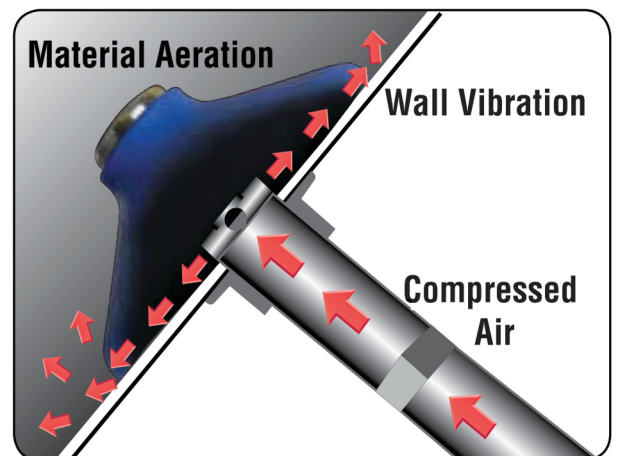

Hopper cutaway shows Fluidizer in use.



Insist on genuine Solimar disks with the trademarked Radial Ridge Design.

Marketed By :

**AIR-LOCK CORPORATION LIMITED**

32 SOI ANAMAI, SRINAKARIN ROAD,  
SUAN LUANG, SUAN LUANG,  
BANGKOK 10250, THAILAND.

**Airlock**

Phone : +66-2118 6150  
Fax : +66-2006 9064  
E-mail : sales@airlockintl.com  
Website : www.airlockcorp.co.th

## Silo Fluidizer Technical Data

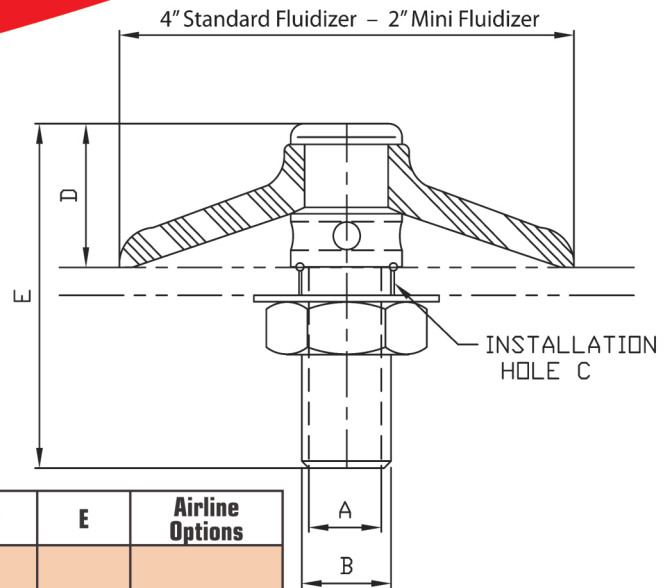

Series	Part #	Stem Material	Disk Color	Disk Material	A	B	C	D	E	Airline Options
4300	4300	Steel	Blue	Silicone	1/4" NPT	1/2" NPT	7/8" (22 mm)	1-3/16" (30 mm)	3" (76 mm)	3/8"-1/2" (10-12 mm) Tubing
	4301		White							
	4302	Aluminum	Blue							
	4303		White							
	4304	Stainless Steel	Blue							
4305	Steel	White								
4400	4400	Steel	Blue	Silicone	1/2" NPT	3/4" NPT	1-1/16" (27 mm)	1-1/4" (32 mm)	3 -1/16" (78 mm)	1/2"-3/4" (13-19 mm) Tubing or Hose
	4401		White							
	4402	Aluminum	Blue							
	4403		White							
	4404	Stainless Steel	Blue							
4405	Steel	White								
4500	4500	Steel	Blue	Silicone	3/4" NPT	1" NPT	1-3/8" (35 mm)	1-1/4" (32 mm)	3-1/4" (83 mm)	3/4"-1" (19-25 mm) Hose
	4501		White							
	4502	Aluminum	Blue							
	4503		White							
	4504	Stainless Steel	Blue							
4505	Steel	White								
MINI	4804	Stainless Steel	Blue	Silicone	1/8" NPT	NA	1/2" (13 mm)	9/16" (14 mm)	1-1/2" (38 mm)	1/4" (6 mm) Tubing
	4805	Steel	White							

Series	AIRFLOW REQUIREMENTS
4300	Capacity 10 – 20 CFM @ 20 – 30 PSI (15 – 30m <sup>3</sup> /h @ 1-2 bar)
4400	Capacity 25 – 40 CFM @ 10 – 20 PSI (40 – 70m <sup>3</sup> /h @ 0.7-1.5 bar)
4500	Capacity 30 – 50 CFM @ 5 – 10 PSI (50 – 85m <sup>3</sup> /h @ 0.3-0.7 bar)
MINI	Capacity 2 – 3 CFM @ 20 – 30 PSI (3.5 – 5m <sup>3</sup> /h @ 1-2 bar)

**Engineering Assistance.** Fax or e-mail a sketch or drawing of your chamber, along with a description of your bulk material and we will provide a recommended number and placement of Fluidizers for your application the next day.

Marketed By :

**AIR-LOCK CORPORATION LIMITED**

32 SOI ANAMAI, SRINAKARIN ROAD,  
SUAN LUANG, SUAN LUANG,  
BANGKOK 10250, THAILAND.

**Airlock**

Phone : +66-2118 6150  
Fax : +66-2006 9064  
E-mail : sales@airlockintl.com  
Website : www.airlockcorp.co.th